

BIESEMEYER®
10" TABLE SAW BLADE GUARD SYSTEMS
(MODEL 78-955 FOR 28", 30" AND 40" T-SQUARE® FENCES)
(MODEL 78-960 FOR 50" AND 52" T-SQUARE® FENCES)

INSTRUCTION MANUAL



PART NO. 1350436
DATED 06-15-2006



BIESEMEYER

To learn more about DELTA MACHINERY visit our web site at: www.deltaportercable.com. For Parts, Service, Warranty or other assistance, please call 1-800-223-7278

To learn more about BIESEMEYER MANUFACTURING visit our web site at: www.biesemeyer.com. For Parts, Service, Warranty or other assistance, please call 1-800-782-1831

INTRODUCTION

The BIESEMEYER® T-SQUARE® Blade Guard System is designed for use on most table saws. The table mount is designed for use on saws equipped with the BIESEMEYER® T-SQUARE® Saw Fence system. The 78-955 and 78-960 are designed for use **ONLY** on Delta 10" Unisaws, 10" Tilting Arbor Saws and 10" Contractors Saws equipped with the BIESEMEYER® 30" or 50" capacity T-SQUARE® fence system respectively.

OSHA regulations and **ANSI** standards require that a splitter and anti-kickback device be utilized for through cutting operations. The 78-955 and 78-960 comply with these regulations.

SAFETY RULES

- 1. FOR YOUR OWN SAFETY, READ INSTRUCTION MANUAL BEFORE OPERATING THE BLADE GUARD SYSTEM.** Learn its application and limitations as well as the specific hazards peculiar to it.
- 2. ALWAYS WEAR EYE PROTECTION.**
- 3. ALWAYS WEAR SAFETY GLASSES** that comply with ANSI 287.1. Everyday glasses only have impact resistant lense; they are not safety glasses. Also use face shield or dust mask if cutting operation is dusty.
- 4. KEEP WORK AREA CLEAN.** Cluttered areas and benches invite accidents
- 5. KEEP CHILDREN AND VISITORS AWAY.** All children and visitors should be kept at a safe distance from the work area.
- 6. USE RECOMMENDED ACCESSORIES.** The use of accessories and attachments not recommended by Delta may cause hazards or risks of injury to person.
- 7. TO PREVENT** injury from kickback or blade contact, use blade guard and splitter whenever the cutting operation permits.
- 8. ALWAYS** use a push stick when cutting narrow stock.
- 9. ALWAYS** stay alert and keep hands out of path of saw blade.
- 10. DRUGS, ALCOHOL, MEDICATION. DO NOT** operate blade guard while under the influence of drugs, alcohol, or any medication.
- 11. WARNING:** The dust generated by certain woods and wood products can be injurious to your health. **ALWAYS** operate machinery in a well ventilated area and provide for proper dust removal. Use wood dust collection systems whenever possible.
- 12. ALWAYS** use blade guard, splitter and anti-kickback fingers for every operation for which it can be used, including all thru-sawing. Thru-sawing operations are those when the blade cuts completely through the workpiece as in ripping or cross-cutting.
- 13. AVOID** awkward operations and hand positions where a sudden slip could cause your hand to move into the cutting tool.
- 14. AVOID KICKBACKS** (work thrown back towards you) by:
 - A. Keeping blade sharp**
 - B. Keeping rip fence parallel to saw blade**
 - C. Keeping splitter and anti-kickback fingers and guard in place and operating.**
 - D. Not releasing the work before it is pushed all the way past the saw blade.**
 - E. Not ripping work that is twisted, warped or does not have a straight edge to guide along the fence.**
- 15. PROVIDE** adequate support to the rear and sides of the saw table for wide or long workpieces.
- 16. NEVER** attempt to free a stalled saw blade without first turning the saw **"OFF."**
- 17. ALWAYS STOP** the saw blade before removing scrap pieces.
- 18. NEVER** perform layout, assembly or set-up work on the table while the saw is running.
- 19. DISCONNECT** saw from power source before changing blades or servicing.
- 20. NEVER** use solvents to clean plastic parts. Solvents could possibly dissolve or otherwise damage the material. Only a soft damp cloth should be used to clean plastic parts.
- 21. SHOULD** any part of your blade guard be missing, damaged, or fail in any way, replace missing, damaged or failed parts before resuming operation.
- 22. SAVE THESE INSTRUCTIONS.** Refer to them frequently and use them to instruct others.

UNPACKING

Carefully unpack the blade guard and all loose items from the carton. Figures 1 and 2 illustrate all items supplied with the Blade Guard System.

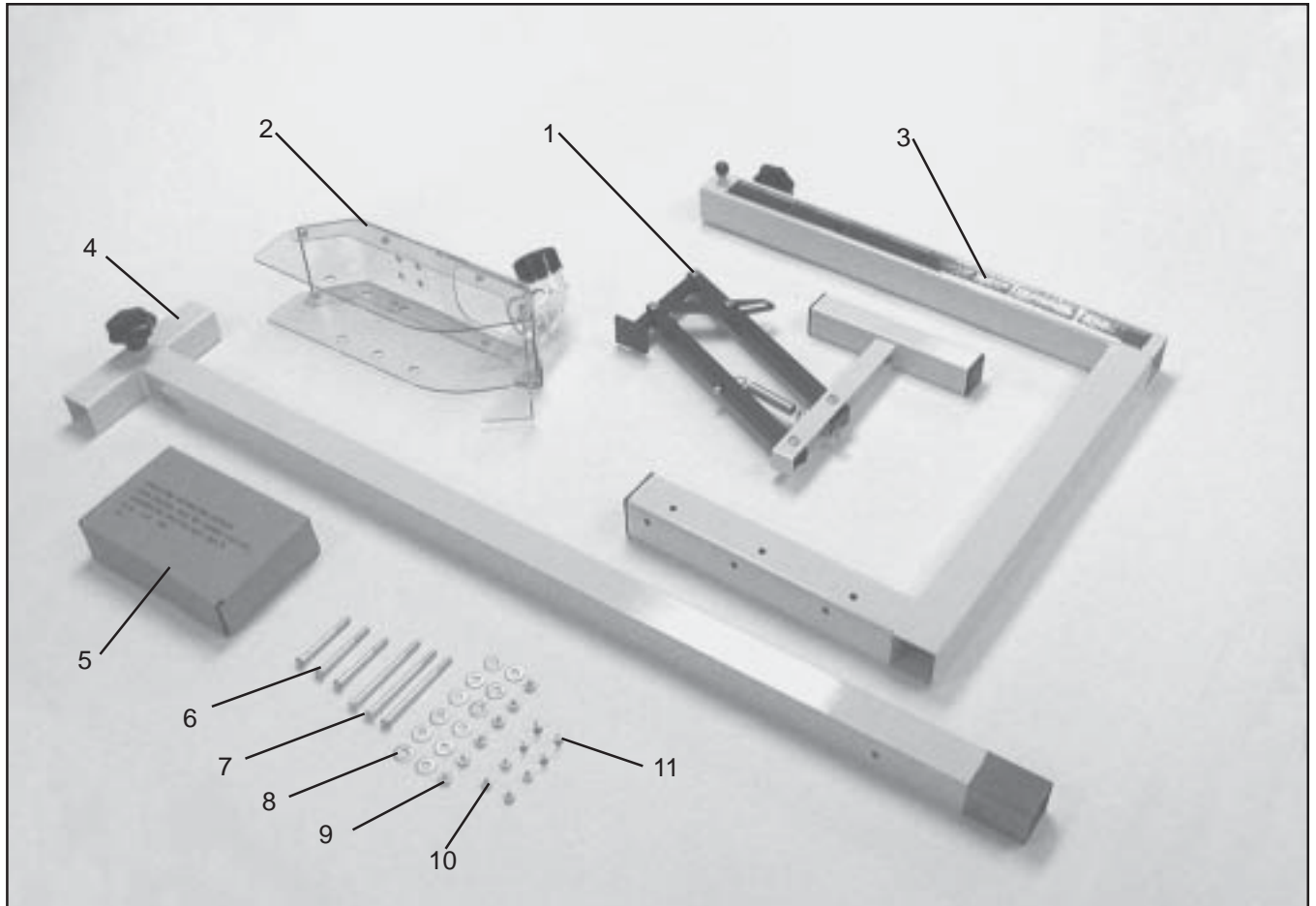

Fig. 1

- 1 - Blade Guard Basket Assembly
- 2 - Basket Body Assembly
- 3 - Guard Mounting Base
- 4 - T-Arm
- 5 - Splitter Assembly (Contents shown in Fig. 2)

- 6 - 1/4-20 x 2-3/4" long hex head screws (3)
- 7 - 1/4-20 x 3-3/4" long hex head screws (3)
- 8 - 1/4" flat washers (12)
- 9 - 1/4-20 hex nuts (6)
- 10 - #10-32 Lock Nut (4)
- 11 - #10-32 x 5/8" Flat HD Screw (4)

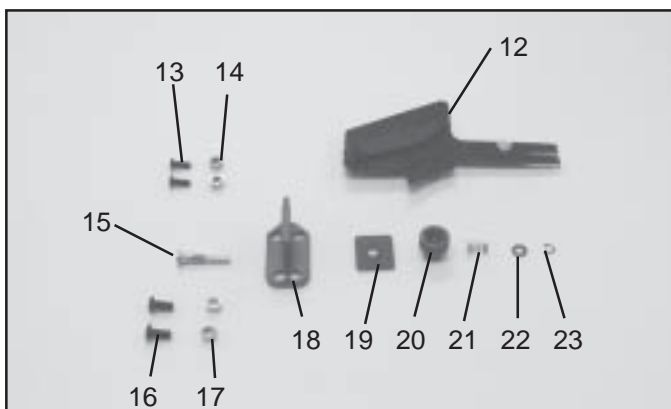

Fig. 2

- 12 - Splitter
- 13 - 1/4-20 x 5/8" button head screws (2)
- 14 - 1/4" bushing (2)
- 15 - Stud
- 16 - 5/16-18 x 5/8" button screws (2)
- 17 - 5/16" bushings (2)
- 18 - Splitter mounting bracket
- 19 - Plate
- 20 - Knob
- 21 - Spring
- 22 - 1/4" flat washer
- 23 - E-ring

INSTALLATION

DISCONNECT THE SAW FROM THE POWER SOURCE!

IMPORTANT: The following instructions for assembling the splitter illustrated in this manual are shown on a Delta 10" left-tilting arbor Unisaw. Assembly to a right-tilting arbor saw will be opposite to what is shown except where noted.

1. Locate the components shown in Fig. 2, for the splitter assembly.

2. Insert and seat stud (A) Fig. 3 through hole in side of splitter mounting bracket (B). NOTE: It will be necessary to have a hammer, punch (C) and a tool with a recessed hole similar to a deep well socket (D) in order to seat stud (A) Fig. 3, and used as shown in Fig. 4.

3. Fig. 5 illustrates stud (A) assembled to splitter mounting bracket for both the left and right tilting arbor saw.

4. Loosely assemble plate (E) Fig. 6, knob (F), spring (G), flat washer (H) and E-ring (J) onto stud (A) as shown assembled in Fig. 7.

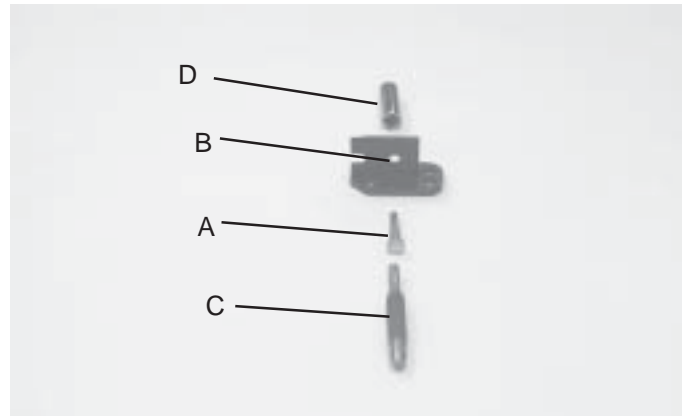

Fig. 3

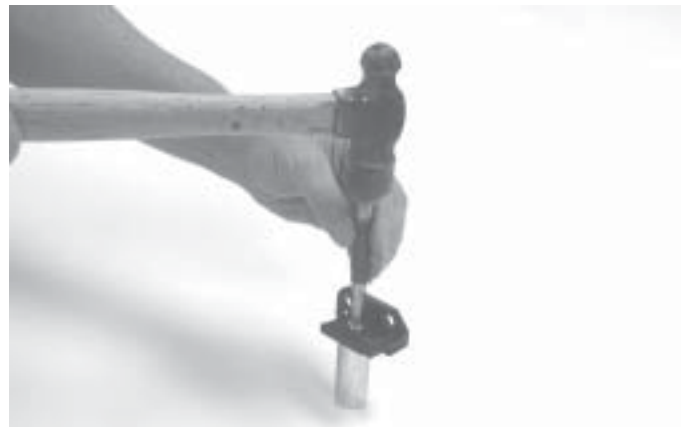

Fig. 4

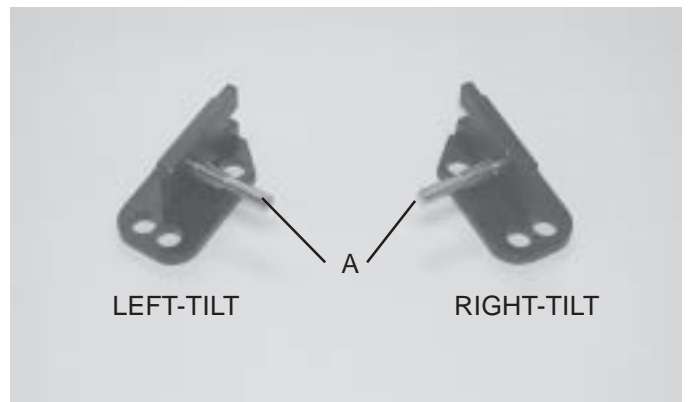

Fig. 5

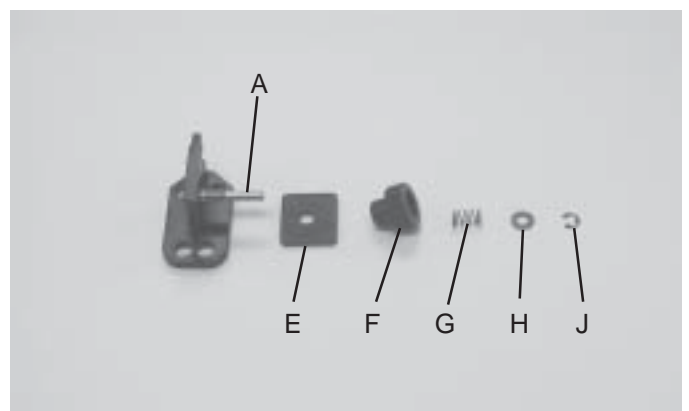

Fig. 6



Fig. 7

5. Locate two bushings each, (K) and (L) Fig. 8, two 1/4-20 x 5/8" button head screws (M); two 5/16-18 x 5/8" button head screws (N) and splitter mounting bracket assembly (P). **NOTE: Bushings (K) with smaller I.D. hole and two 1/4 x 5/8" long screws (M) are used when mounting the splitter to the Delta 10" tilting arbor saw and the 10" Contractors saw. Bushings (L) Fig. 14, with the larger I.D. holes and two 5/16-18 x 5/8" long button head screws (N) are used when mounting the splitter bracket to a 10" Unisaw.**

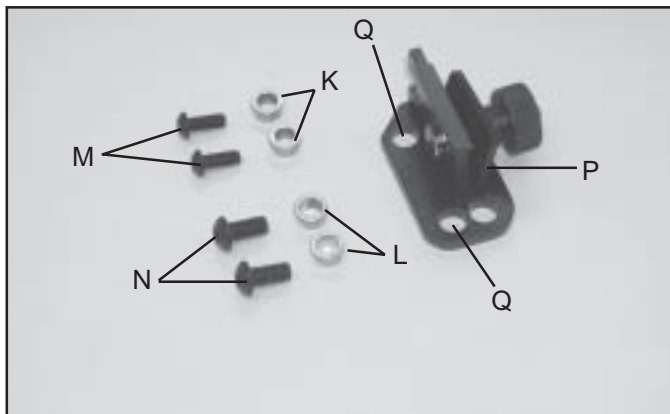

Fig. 8

6. Depending on what saw you are using, insert bushings (K or L) Fig. 8, into holes (Q) in the splitter mounting bracket.

7. Remove the saw blade from the saw arbor.

8. Assemble the splitter mounting bracket (P) Fig. 9, to the inside of rear trunion using two button head screws (N) Figs. 8 and 9, since we are mounting the splitter to a 10" Left tilting Arbor Unisaw. **NOTE: Just snug up button head screws at this time.**

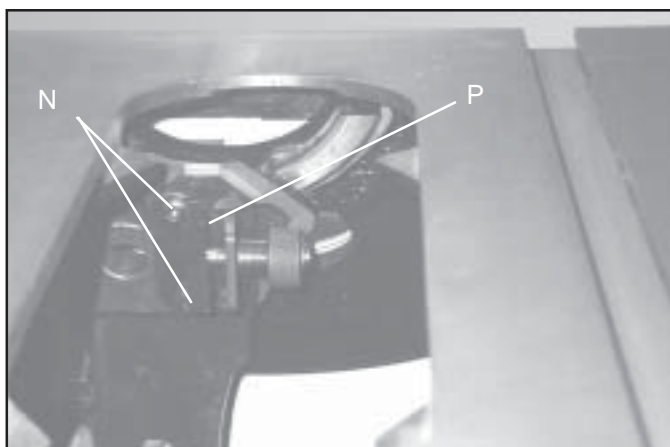

Fig. 9

9. Using a straight edge (R) Fig. 10, align the top portion of splitter mounting bracket (P) to saw arbor (S) as shown. Then tighten two screws (N) Fig. 9.

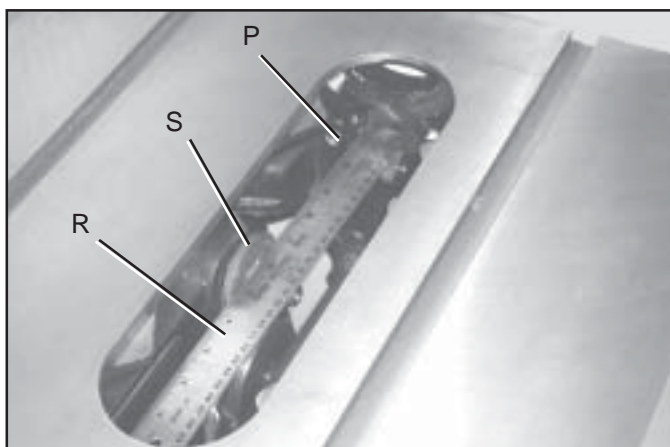

Fig. 10

10. Insert index pin (T) Fig. 11, through the hole in splitter (U), as shown, and fasten with locknut (V). Fig 11 illustrates the index pin assembly arrangement for both right and left tilting arbor saws.

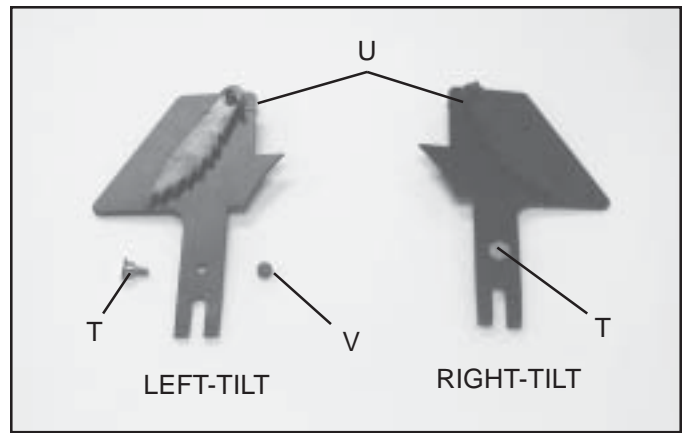

Fig. 11

11. Loosen knob (F) Fig. 12, and slide splitter (U) down as far as possible into the splitter mounting bracket and tighten knob (F). Fig 13 illustrates the splitter assembled to the mounting bracket. **IMPORTANT:** When performing non thru-cutting operations, such as dadoing, the splitter (U) Figs. 12 and 13, can be removed by loosening knob (F). This enables you to use the guard basket for non thru-cutting operations.

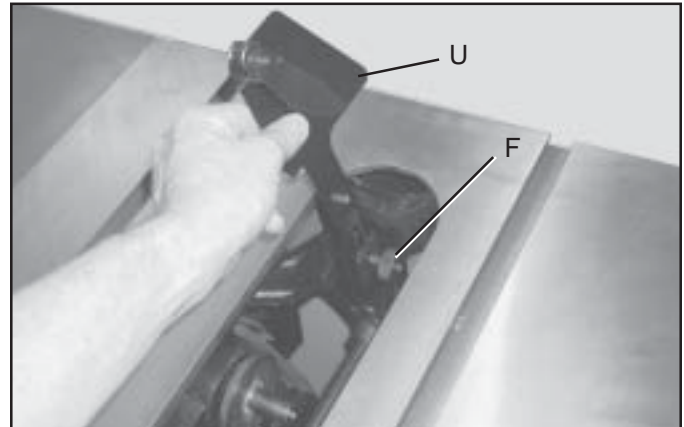

Fig. 12

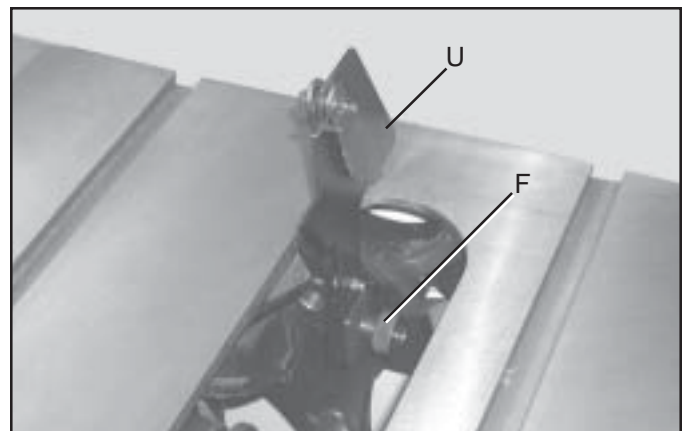

Fig. 13

GUARD ASSEMBLY

12. Clamp the guard mounting bracket (A) Fig. 14 to the back rail (B) of the fence system, making sure the inside of the vertical post (C), is approximately 1/4" past the end of rail (B).

13. Using a 9/32" drill bit, drill six holes in the rear rail, three each to be drilled into the horizontal and vertical portion of the back rail (B), using the holes (D) and (E) in the mounting bracket as a template.

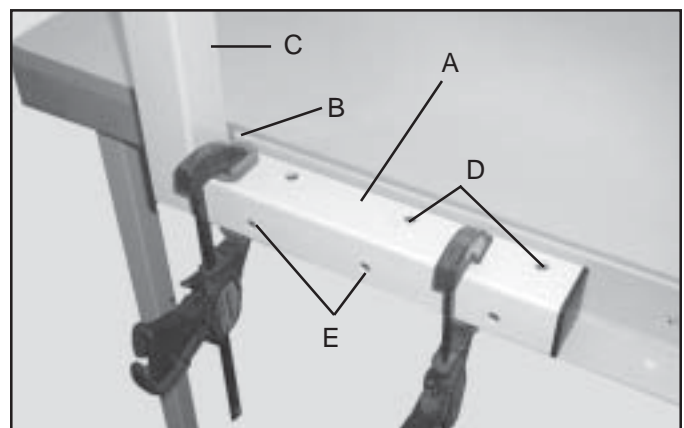

Fig. 14

14. Fasten the mounting bracket (A) Fig. 15, to the back rail (B) using the three 2-3/4" long hex head screws (F), three 3-3/4" long hex head screws (G), twelve 1/4" flat washers and six 1/4-20 hex nuts. Place one flat washer on each hex head screw before inserting through the guard mount bracket. Then place the remaining washers on the hex head screws and secure with the six 1/4-20 hex nuts.

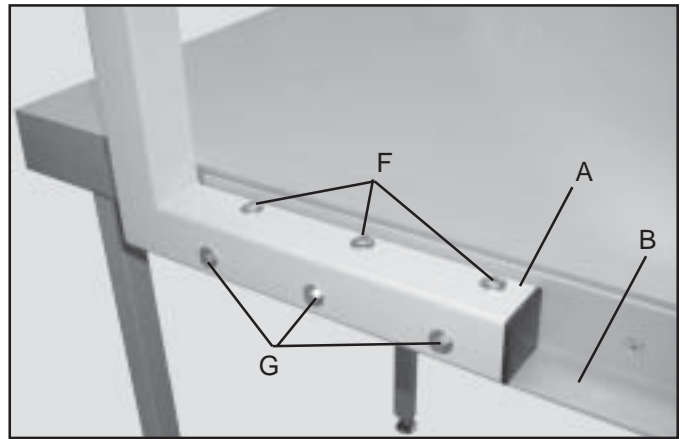

Fig. 15

15. Thread knob (H) Fig. 16, into mounting bracket (A) as shown. Insert T-arm (J) Fig. 16, into mounting bracket (A).

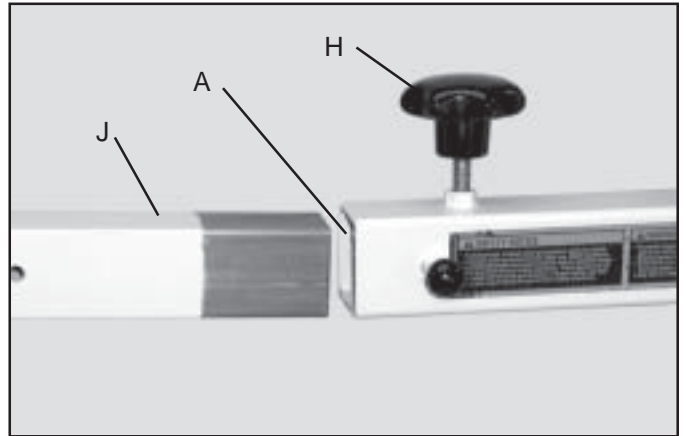

Fig. 16

16. Pull stop pin (K) Fig. 17, to allow the T-Arm to slide past stop pin indexing hole (L).

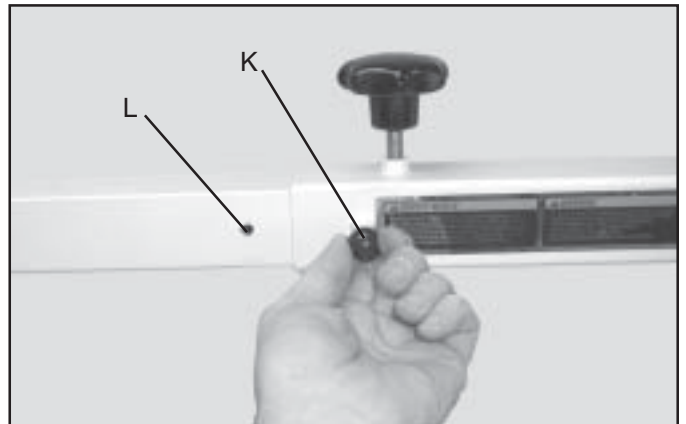

Fig. 17

17. Assemble basket body assembly (M) Fig. 18, to blade guard basket assembly (N) using the four (4) #10-32 x 5/8" flat head screws (P) and four (4) #10-32 locknuts (Q). Do not completely tighten screws at this time.

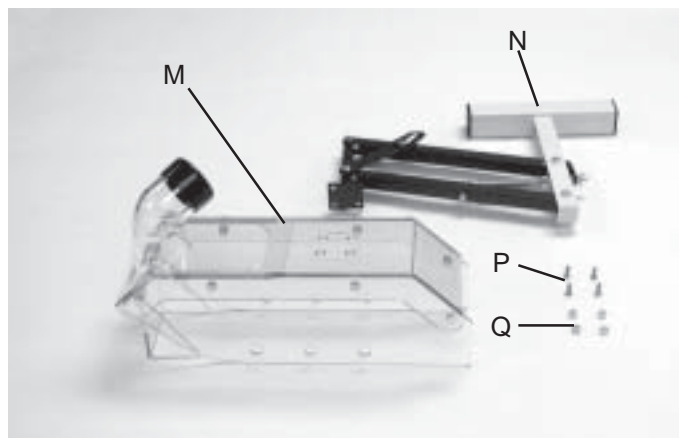

Fig. 18

18. Make certain the hood assembly (M) Fig. 19, is in line with the basket body assembly (N). When you are certain hood assembly (M) is in line with basket body assembly (M), tighten 4 screws (P).

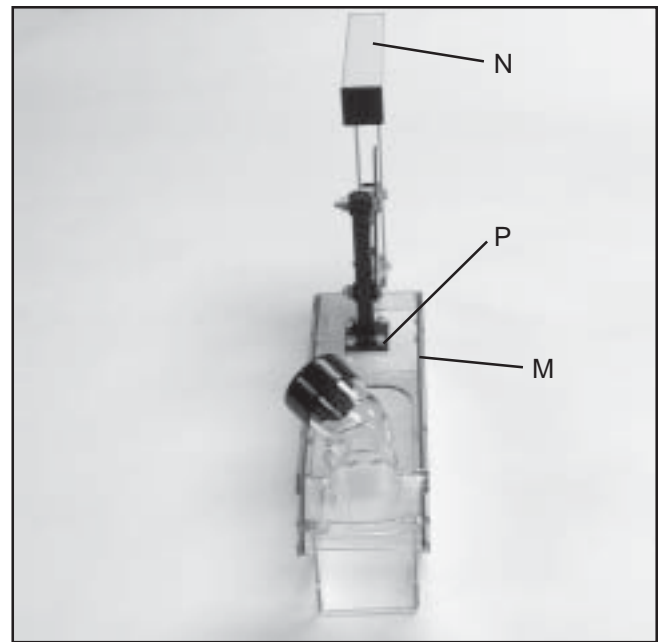

Fig. 19

19. Thread locking knobs (R) Fig. 20, into threaded nut on adjusting arm (J). Insert basket body assembly (N) Fig. 20 into the "T" of the adjusting arm (J).

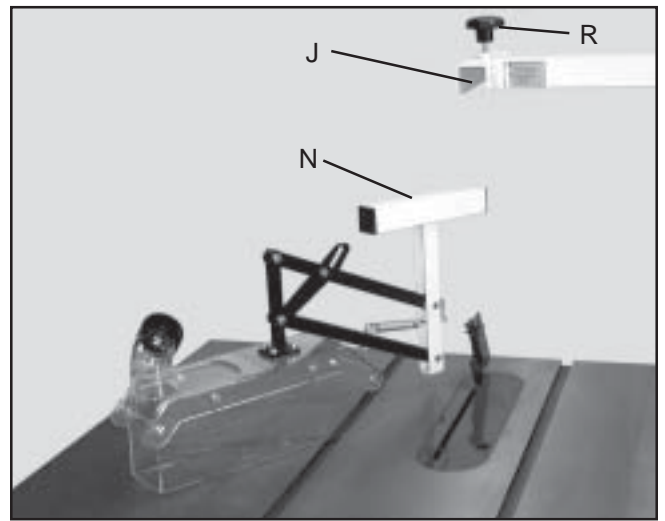

Fig. 20

20. Loosen the two locking knobs (R) & (H) Fig. 21, and adjust T-arm (J) and blade guard basket assembly (N) until the guard basket (M) is centered over the saw blade.

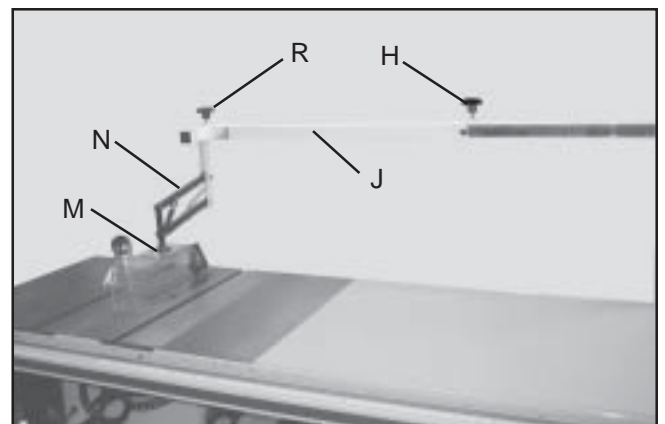

Fig. 21

21. **IMPORTANT:** Make certain the rear end of the guard basket frame (M) Fig. 22, is 3/8" away from the front of the splitter (S) and tighten the two locking knobs (R) and (H) Fig. 21.

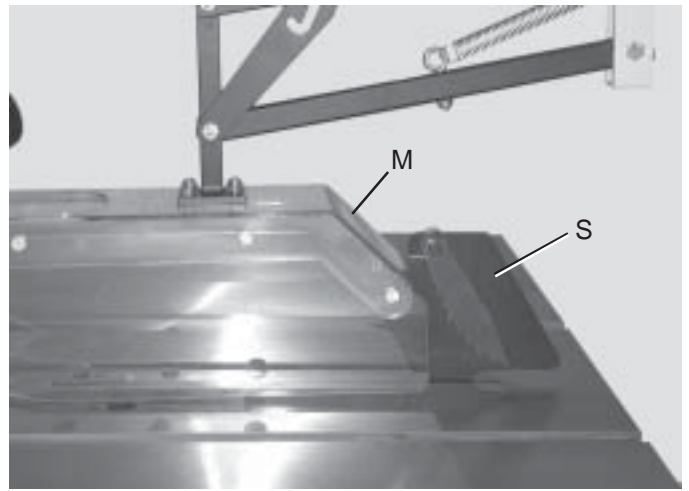

Fig. 22

22. To raise the guard basket (M) Fig. 23, above the saw blade, simply lift up the hood by the dust port until guard catch (T) engages hex head bolt (U) as shown in Fig 24. It may be necessary to loosen hex head bolt (U) to allow the guard catch (T) to fall back to engage bolt (U).
NOTICE: DO NOT LIFT THE GUARD BASKET FROM ANY OTHER POINT EXCEPT THE DUST PORT!

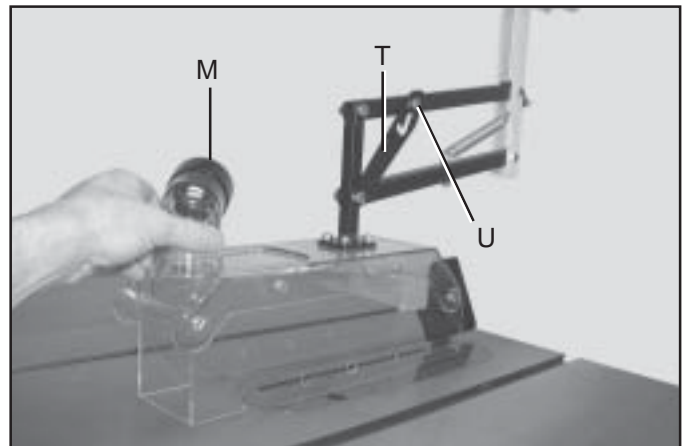

Fig. 23

23. To lower the guard basket assembly (M) pull forward on guard catch (T) Figs. 24 & 25.

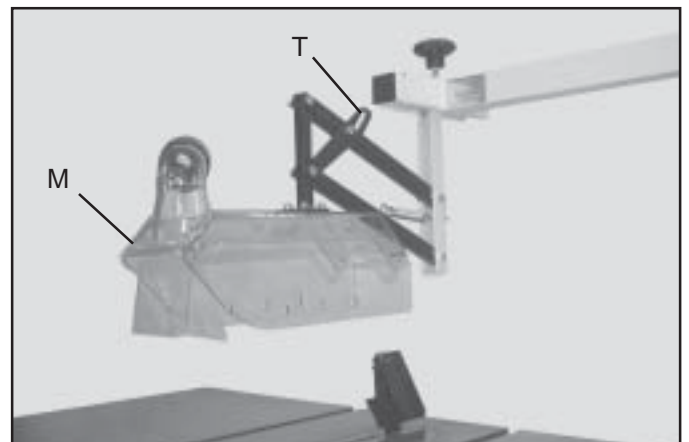

Fig. 24

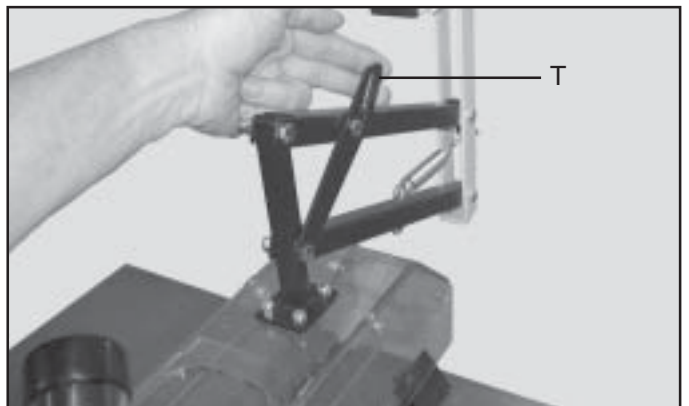

Fig. 25

24. There is an adjustment screw to achieve the desired weight of the guard basket (M) Fig. 27, on the workpiece. To make an adjustment, loosen locknut (V) Fig. 26, and turn wing nut (W) clockwise to decrease the pressure or counter-clockwise to increase the pressure. After the desired pressure is achieved, tighten locknut (V).

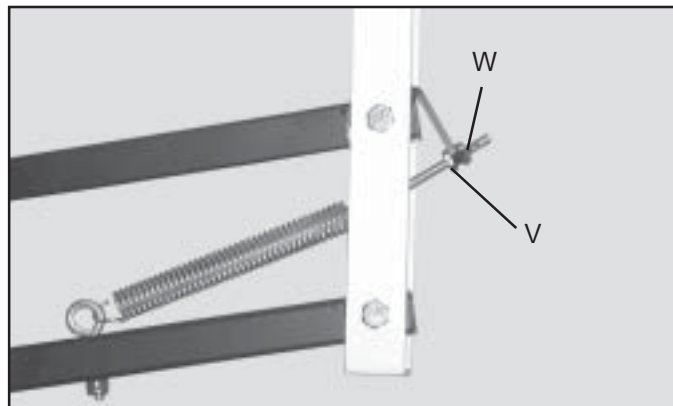

Fig. 26

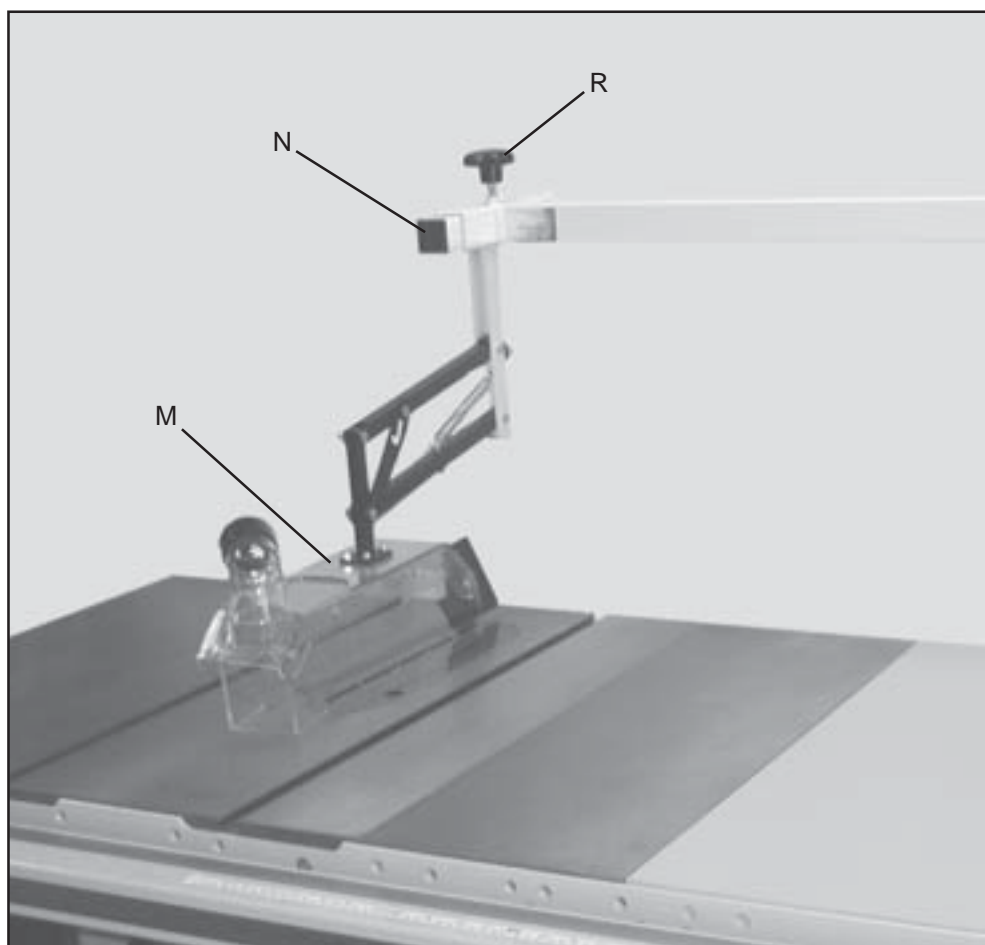

Fig. 27

25. Front to back movement of the blade guard basket (N) Fig. 27, is obtained by loosening locking knob (R) and sliding basket body arm (N) in or out as desired. Always tighten locking knob (R) after adjustment is complete. NOTICE: IT IS RECOMMENDED THAT THE BACK OF HOOD ASSEMBLY (M) BE POSITIONED 3/8" IN FRONT OF THE SPLITTER BLADE.

NOTICE: BEFORE MAKING ANY ADJUSTMENTS TO THE GUARD BASKET ASSEMBLY, DISCONNECT THE SAW FROM THE POWER SOURCE AND MAKE CERTAIN THE SAW BLADE HAS STOPPED TURNING COMPLETELY!

26. Left to right movement of the blade guard basket (M) Fig. 28, is obtained by loosening locking knob (H) and sliding the T-Arm (J) to the left or right. Always tighten knob (H) after adjustment is completed.

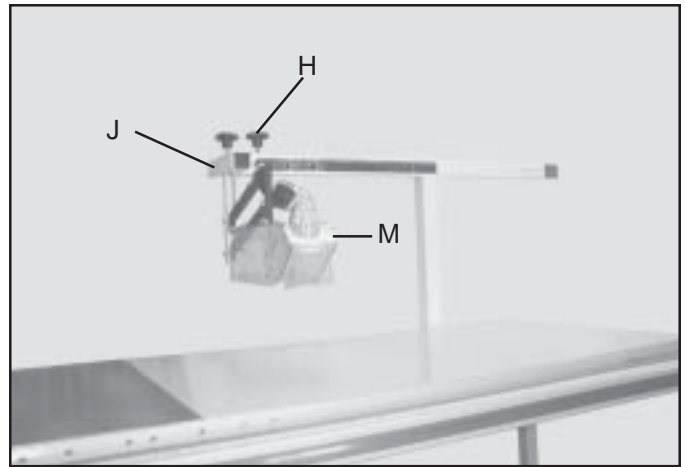

Fig.28

27. The blade guard mount bracket has a stop pin (K) Fig. 29 that engages hole (L) in the blade guard T-Arm. This is to prevent the T-Arm from being completely pulled out of the guard mount bracket (A). If the T-Arm must be removed from the guard mounting bracket, loosen knob (H), slide T-Arm (J) to the left until stop pin (K) engages hole (L). Pull pin (K) and continue to slide the T-Arm out.

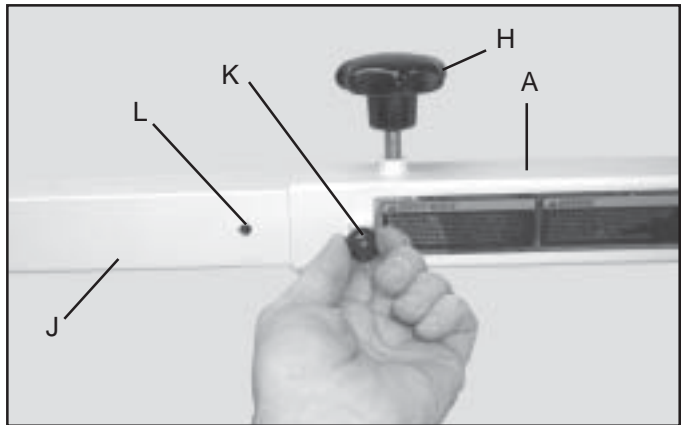

Fig.29

28. It is recommended that T-Arm (J) be waxed on a weekly basis to allow it to move freely inside the guard mount bracket. Meguiar's M-2611 paste wax is recommended.

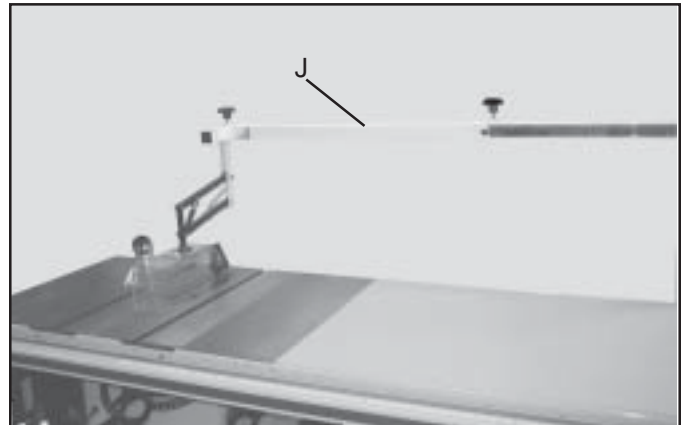

Fig.30



TWO YEAR LIMITED WARRANTY

Delta will replace, at its expense and at its option, any Delta machine, machine part, or machine accessory which in normal use has proven to be defective in workmanship or material, provided that the customer notifies his supplying distributor of the alleged defect within two years from the date of delivery to him, of the product and provides Delta Machinery with reasonable opportunity to verify the defect by inspection. Delta Machinery may require that electrical motors be returned prepaid to the supplying distributor or authorized service center for inspection and repair or replacement. Delta Machinery will not be responsible for asserted defect which has resulted from misuse, abuse or repair or alteration made or specifically authorized by anyone other than an authorized Delta service facility or representative. Under no circumstances will Delta machinery be liable for incidental or consequential damages resulting from defective products. This warranty is Delta Machinery's sole warranty and sets forth the customer's exclusive remedy, with respect to defective products; all other warranties, express or implied, whether of merchantability, fitness for purpose, or otherwise, are expressly disclaimed by Delta.